

Machinist's Guide to Toolholder Maintenance

For Collet & Nut Style Toolholders

General Overview

Modern CNC machines feature high-capacity tool changers that automatically swap toolholders in and out of the spindle as needed, by means of a high speed swing arm or a rotary carousel. Periodically, toolholders should be examined for wear and if necessary replaced to maintain cutting performance.

New operators should be taught how to properly evaluate toolholders so they can recognize when toolholders need to be replaced to prevent premature cutting tool failure, or even expensive damage to the spindle. Many operators do not know why it is necessary to replace their tooling, or have the experience to tell when it is time to do so.

Determining if toolholder components need to be replaced is not a difficult task, but does require that the operator knows what to look for. This article will cover the criteria used to evaluate collet and nut style toolholders, describe when and why it is necessary to replace them and the implications of not replacing them.



Example of a collet and nut style toolholder

Sizing Toolholders

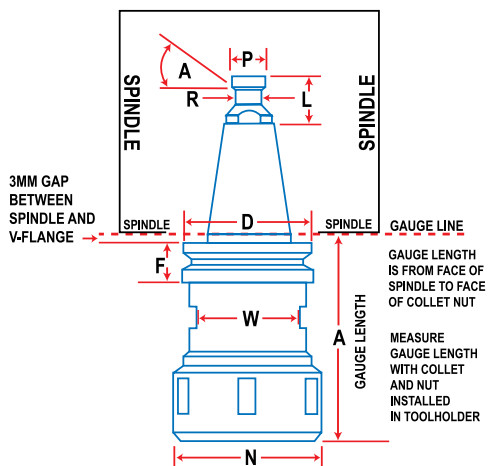

There are different types of holders that have other means of holding the cutting tool, such as shell mill arbors, end mill holders, and shrink-fit. This article deals with collet & nut type holders.

Careful measurement of toolholder dimensions may be necessary for exact replacement if the part number or description has worn off.

A typical size description of a toolholder is CAT40 x ER 32. The "CAT" refers to the flange type, "40" is the taper size, and "ER 32" is the type and size of collet that fits into the pocket. The other dimension to be aware of is the "Gauge Length". This refers to the distance the toolholder extends from the face of the spindle (see diagram.)



Parts of a Toolholder

A general understanding of toolholder components and their functions is important. There are four main parts to a toolholder (also known as a collet holder or collet chuck).

Pull Studs



Pull Studs (also called retention knobs) are extremely important because they keep the toolholder in the spindle. Using worn pull studs or using the wrong pullstud for your machine may cause the toolholder to suddenly fly out of the spindle during operation, causing an unsafe situation for the machine operator.

The pull stud screws into the top of the taper of the toolholder. Some pull studs are hollow, to permit coolant to flow thru the toolholder. When in use, the pull stud is held by the clamping set inside the spindle which pulls the holder up into the spindle mouth. A spring-loaded draw bar pulls the holder into place.

Taper

The taper is the conical shaped area of the toolholder that enters the spindle when changing the tool. An 8 degree taper automatically centers the tool into the spindle. The taper is accurately ground to a tolerance of .0002" for both the taper tolerance and outside diameter tolerance. Some toolholders like HSK have a shorter taper than BT or CAT style (see illustration)

V-Flange

The v-flange is the part of the toolholder that the automatic tool changer locks onto when moving the tool from the tool changer to the spindle and back again. The flange is visually identified as the "V" groove found on the outer most diameter of the toolholder. Cutouts in the flange help orientate the holder in the spindle.

Collet Pocket, Collet, & Nut

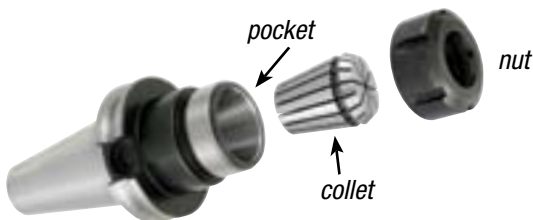

The last part of the toolholder is the collet pocket, into which the collet is inserted before being secured by various types of collet nuts.

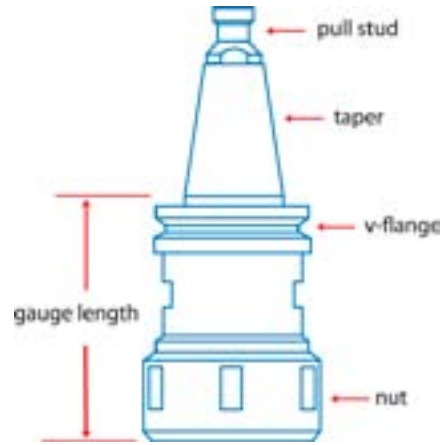

Parts of a collet and nut style toolholder

Drawbar Assembly

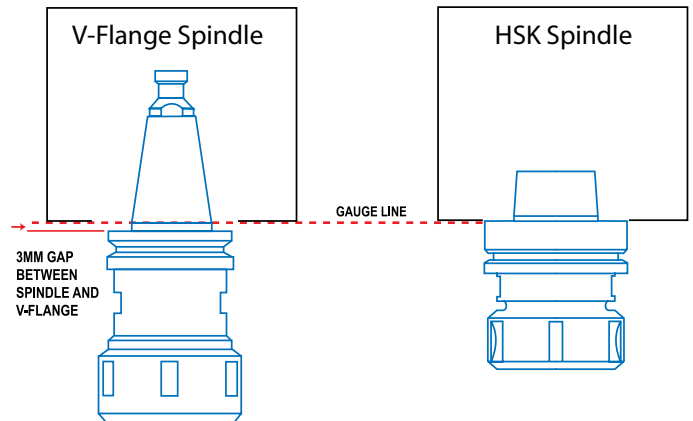

Note how HSK taper (right) is a dual-contact taper. Meaning that it is flush with the gauge line of the spindle face, creating dual contact between the flange of the holder and the spindle face, and the taper itself and the spindle mouth. Dual contact increases toolholder rigidity for improved performance especially at extended gauge lengths. Techniks DualDRIVE toolholders provide dual contact on V-flange (BT, CAT) spindles.

The cutting tool is held by the collet, which is designed to collapse around the shank of the tool as the nut is tightened, pushing the collet deeper into the collet pocket until maximum clamping pressure is achieved by the Power Coat nut.

Checking For Spindle Mouth Wear

A worn spindle can cause runout issues that affect toolholder accuracy and reduce cutting quality and productivity. This is a condition known as bell mousing. If toolholder issues can be eliminated by bench checking T.I.R., then the source of the problem is often a worn out spindle mouth. A trained professional will be required to check and repair bell mousing.

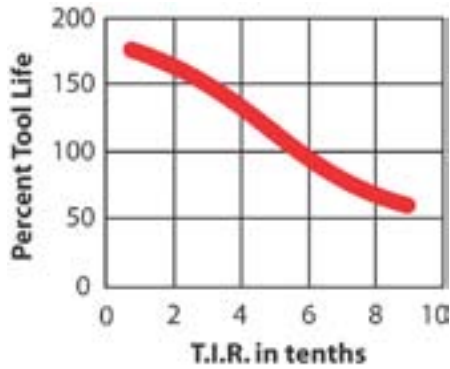

You lose 10% of cutting tool life for every "tenth" (0.0001") of runout

ATC Alignment Issues

It's crucial to maintain proper ATC swingarm alignment. If the ATC does not insert the toolholder perfectly, damage to the spindle and toolholder may result. Also poor cutting tool performance and reduced tool life will be evident.

Evaluating Toolholders for Wear

A worn out holder will not provide good accuracy and will quickly wear out your cutting tools. Worn tooling causes poor surface finish, and may damage your spindle.

Taper Wear / Fretting

Check the taper for signs of wear or damage where it contacts the spindle mouth. Any problems with the taper will have a direct effect on machining accuracy. If there are any imperfections on the taper, the toolholder should not be used.

If noticeable marking is evident on the taper (see photo to next page) a condition called fretting may be occurring. Fretting happens when two steel parts (holder and spindle mouth) are rubbing against one another. Fretting is caused by imperfect mating between toolholder taper and spindle, creating vibration and heat which develops the fretting. It is visible as small copper colored pits or marks on the taper. This is evidence that the toolholder is becoming worn. Fretting is easily mistaken for rust, but it is not. Once noticeable fretting develops the toolholder should be replaced. New toolholders that quickly develop fretting, or toolholders that stick in the spindle, may indicate a spindle that needs to be reground.

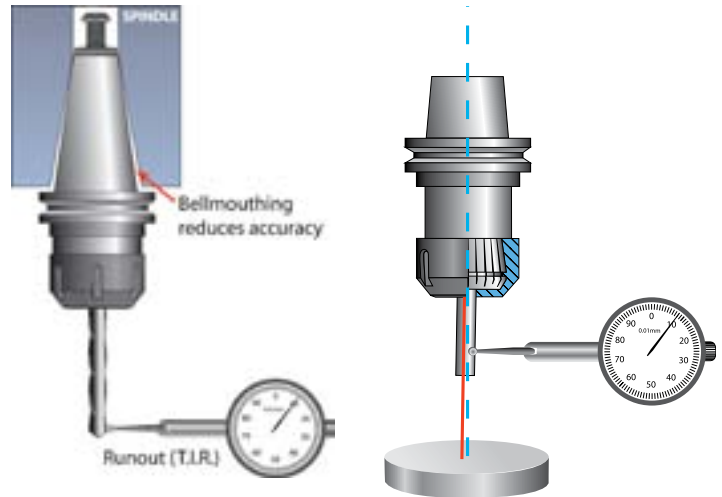

T.I.R. (total indicator runout) is the measurement of axial deflection of the cutting tool in the toolholder assembly. Techniks toolholders are manufactured to minimize runout and extend cutting tool life.

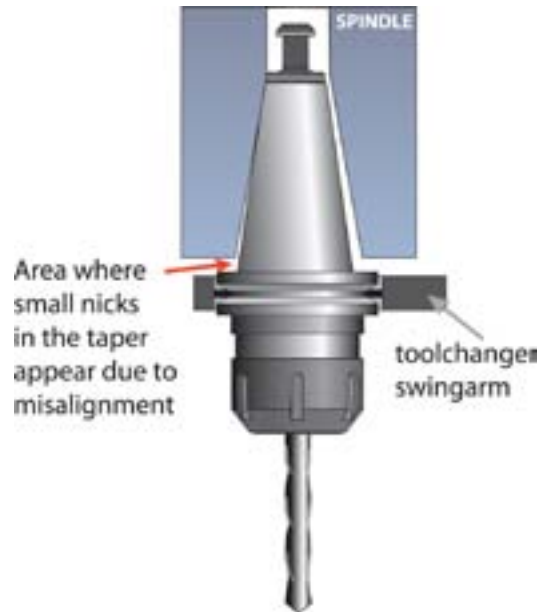

Fretting (wear marks) on a toolholder taper.

A worn taper causes an out-of-round condition when the holder is inserted into the spindle. This is called “runout”. Runout causes premature tool wear and excessive vibration during operation. This vibration can cause poor surface finish which may require additional operations to correct. Vibration can also cause heat build-up in the spindle and damage spindle bearings. See our video on youtube to learn how to check toolholder T.I.R. Search for “How to check runout”.

Collets

Collets are manufactured from softer metal than toolholders and feature special slots and cutouts allowing them to “collapse” and “spring” to tightly grip the cutting tool. As a result, they will wear out faster than the holders will. Worn collets will cause cutting tools to fail prematurely, costing manufacturers thousands of dollars in preventable costs. Collets should be replaced whenever wear is evident so the accuracy and performance of the cutting tool / toolholder assembly is maintained.

If there is any damage to the outside or inside diameter (I.D.) of the collet it must be replaced. Look for scoring marks in the I.D. where cutting tools may have spun in the collet, causing damage. Once damaged, collets cannot grip the tool shank effectively, so holding power and accuracy are reduced.

While there is no standard rule of thumb for replacing a collet, some common causes to replace them would include: If a tool is broken off while in the collet and it has scored or marked the inside or outside of the collet in any way, it should be replaced, or if the collet is kept in a very humid environment and not sprayed with rust preventative, and has been allowed to rust or pit, it should be replaced.

When a tool holder is not being run for a job and is taken out of the machine, it should be wiped clean and have a light coating of a rust preventative sprayed on it. When the time comes to place that tool back into service, it should have the “oil” wiped off of it before it is placed back into the spindle. Care should also be taken that the coolant used is also of the correct concentration, so that it does its job of not only cooling the part, but also preventing rust on the tool holders.



Scoring on collets that spun in the pocket due to inadequate holding power from the nut.

Collet Nuts

In order for the toolholder to be balanced and maintaining accuracy while machining, it must have a balanced nut. Many manufacturers use bearing nuts with their collets. However, since bearing nuts have moving parts (nut, bearing race, bearings) they are difficult to keep balanced, and prone to seizure if the seals fail.

We recommend using “Power Coat” nuts instead. Power Coat nuts are balanced and provide 75% more holding power on the tool shank, providing increased accuracy and rigidity that is necessary when machining under side loads. Because they are balanced and more rigid they extend cutting tool life significantly.



Cut-away view of a bearing nut showing bearings and seals.

Pull Studs (retention knobs)

The pull stud is a critical safety component because it maintains the connection between the spindle and the toolholder. If that connection fails, the holder will dangerously fly out of the spindle.

Check the pull studs periodically for signs of wear, cracks, or other damage, and replace any that are not perfect or a dangerous situation may result.



Marks on the end of a pull stud that is either not correct for the machine spindle gripper, or the gripper is damaged.

Preventive Maintenance

To insure proper performance of your toolholders, overall cleanliness of toolholder, collet pocket, collet, and nut must be maintained. It's important to remember that all these components are manufactured to perform within tolerances of ten-thousandths (.0001") of an inch. Any dirt, dust, oil, chips, or other contaminant left on the spindle, taper, flange, collet, collet pocket, or nut can cause poor T.I.R. (runout) leading to premature wear of cutting tool, toolholder, and spindle mouth. We recommend a regular preventive maintenance program be implemented in your shop to protect your investment in cutting tools, toolholders, and collets, and reduce scrap.



Spindle wipers are the best way to prevent contaminants from building up in your spindle mouth.

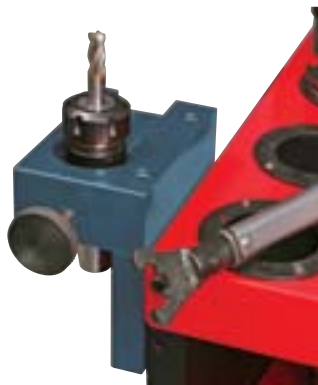

Use tightening stands and a torque wrench every time you change out a collet or pullstud. Proper torque is essential to collet & nut toolholder performance.

A program that includes cleaning and checking your spindle, toolholder tapers, collet pockets, collets, and nuts with every use will go a long way towards improving your CNC machine performance and protecting your ROI.

Regularly bench checking the T.I.R. of your collet & nut toolholder assemblies is also recommended to identify toolholders which are wearing out of spec. It's important to use a tightening stand and torque wrench to properly tighten pull studs and collet nuts to maintain shop safety and prevent premature damage to collets and collet pockets due to over-tightening. To prevent contaminants from entering the collet pocket, we recommend using inexpensive Black Gold rings to seal the pocket during operation.

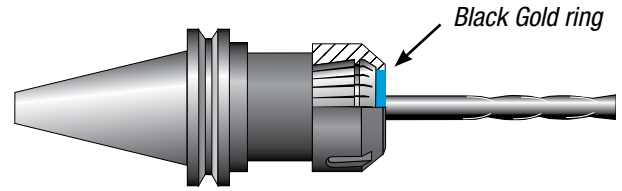

Black Gold rings are sized to fit the tool shank and seal the pocket from contaminants, protecting both the collet and collet pocket.

Summary

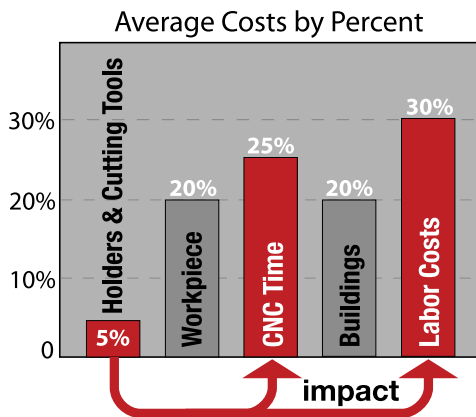

The most cost-effective way to increase your CNC machine productivity, reduce down-time, and reduce scrap while maintaining part quality is proper care and use of your toolholders. Toolholders are a small proportion of machining costs, but can have a big impact on productivity and ROI.

Collets and tool holders are made out of metal, and if not taken care of, they will rust and pit. If worn or damaged tooling is allowed to run in a good quality spindle, they will cause premature failure of the spindle.

The information published here is educational in nature and intended to provide general guidelines for the care and maintenance of toolholders, collets, nuts, and CNC machine spindles based upon our years of experience manufacturing toolholders and troubleshooting toolholder issues for our customers. It is not intended to be a rigid set of practices as not all toolholders are manufactured to the same standards as ours, and your results may vary depending upon your CNC machine condition, the quality of your toolholders, and the conditions under which they are used.



Regular bench checking of collet and nut toolholder assemblies using a gauge pin will quickly identify any T.I.R. issues.